



MACHINE TOOLS EQUIPMENTS

1071

KOMBI-STALHALTER FÜR STECH-UND TANGENTIALSTAHL (GERADE) **D**

PORTAUTENSILE DA TAGLIO MODULARE REGISTRABILE TANGENZIALE **I**

TOOLHOLDER CUT MODULAR SIZING TANGENTIAL **GB/USA**

PORTE-OUTIL COUPE MODULAIRE REGLAGE TANGENTIEL **F**

PORTAUTIL CORTE MODULAR REGULACION TANGENCIAL **S**



TABELLA PAGINA SEGUENTE

TABLE NEXT PAGE

A RICHIESTA PER ALTRI TIPI DI MACCHINA - ON REQUEST FOR OTHER TYPES OF MACHINE

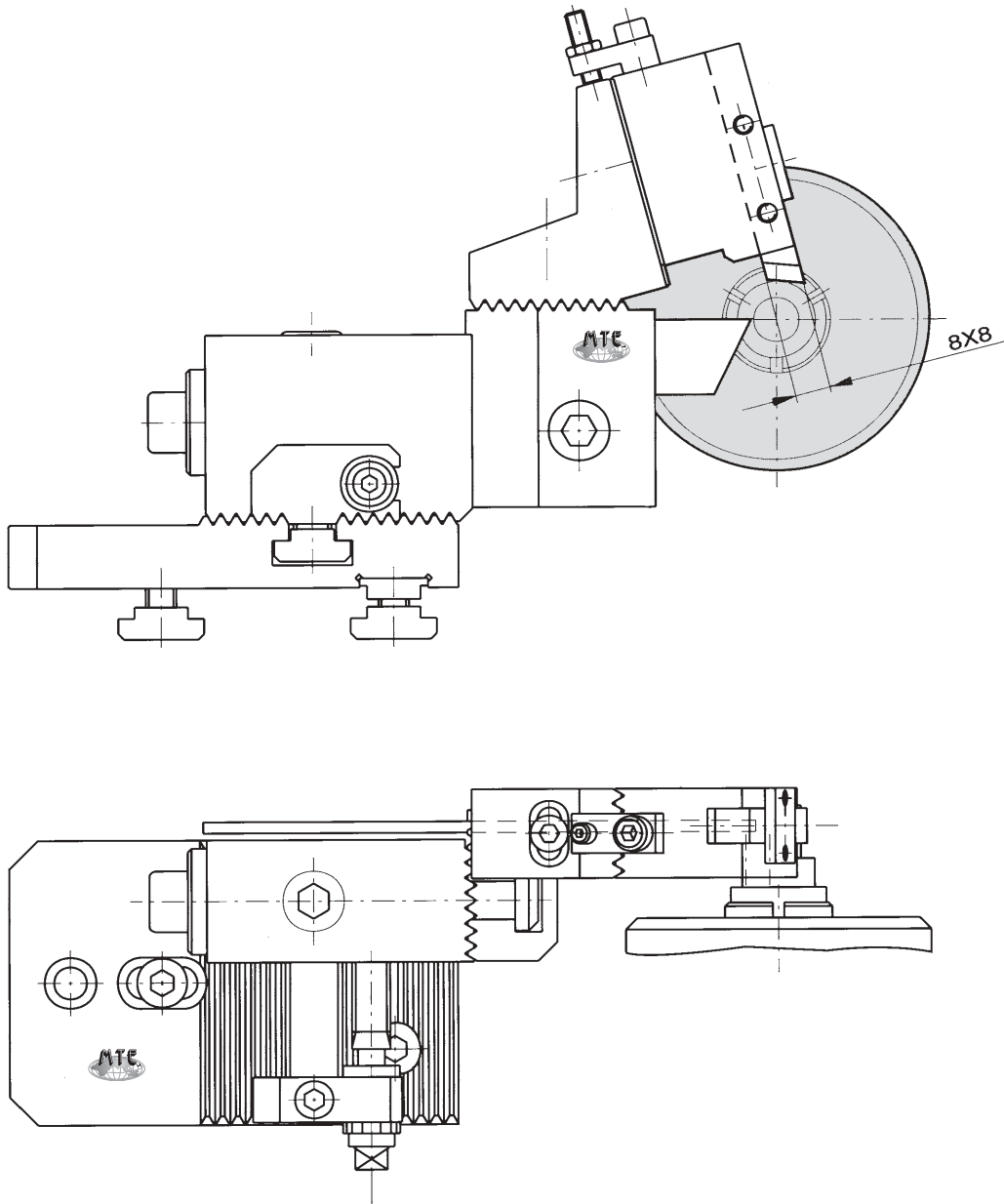

MACHINE TOOLS EQUIPMENTS

107.1

KOMBI-STALHALTER FÜR STECH-UND TANGENTIALSTAHL (GERADE)

D

PORTAUTENSILE DA TAGLIO MODULARE REGISTRABILE TANGENZIALE

I

TOOLHOLDER CUT MODULAR SIZING TANGENTIAL

GB/USA

PORTE-OUTIL COUPE MODULAIRE REGLAGE TANGENTIEL

F

PORTAUTIL CORTE MODULAR REGULACION TANGENCIAL

S

A RICHIESTA ALTRE ATTREZZATURE/FURTHER EQUIPMENTS ON REQUEST

ARTICOLO ARTICLE	MACCHINA MACHINE	LAMA EMPIRE EMPIRE CUTTER	b x h
WICKMAN			
107.10.10	5/8"	1.6x12	8x8
107.17.10	7/8" - 5 M	2.5x17	8x8
107.19.10	1" 3/4 - 5 M	2.5x17	8x8
107.20.10	1"	2.5x17	8x8
107.29.10	32 - 8	2.5x17	8x8
107.30.10	1" 3/4-3/8	2.5x17	8x8
107.38.10	1" 3/8 - 5 M	2.5x17	8x8
107.40.10	2" 1/4	3.2x22	8x8
107.41.10	2" 5/8	3.2x22	8x8
107.50.10	3" 1/2	3.2x22	8x8
107.58.10	3" 1/4	3.2x22	8x8
GILDEMEISTER			
107.09.10	AS 12	1.6x12	8x8
107.11.10	AS 16 - GM 16	1.6x12	8x8
107.15.10	AS 20 - GS 20 - GM 20	1.6x12	8x8
107.18.10	AS 22 - AS 25	2.5x17	8x8
107.27.10	AA 32	2.5x17	8x8
107.31.10	AS 32	2.5x17	8x8
107.32.10	AS 40 - AS 48	2.5x17	8x8
107.36.10	AA 48	2.5x17	8x8
107.44.10	AS 55 - 67	3.2x22	8x8
107.47.10	GM 35 - GM 42	2.5x17	8x8
107.51.10	AA 67	3.2x22	8x8
107.56.10	GM 32	2.5x17	8x8
107.63.10	AS 63	3.2x22	8x8
107.69.10	GS 50 - 51	3.2x22	8x8
107.70.10	GM 26	2.5x17	8x8
107.82.10	AS 82	3.2x22	8x8
107.83.10	AS 100	3.2x22	8x8
MORI SAY - EUROTURN			
107.14.10	6/20	1.6x12	8x8
107.24.10	6/25 - 6/32	2.5x17	8x8
107.28.10	6/42	2.5x17	8x8
107.53.10	8/32	2.5x17	8x8
107.67.10	8/42	3.2x22	8x8
INDEX			
107.13.10	MS 25	1.6x12	8x8
107.34.10	KS 25	2.5x17	8x8
107.35.10	KS 42	2.5x17	8x8
107.60.10	KS 18	2.5x17	8x8
107.61.10	KS 32	2.5x17	8x8
107.62.10	KS 50	2.5x17	8x8

ARTICOLO ARTICLE	MACCHINA MACHINE	LAMA EMPIRE EMPIRE CUTTER	b x h
SCHÜTTE			
107.08.10	SF 13	1.6x12	8x8
107.21.10	SE 16 - SF 20	2.5x17	8x8
107.22.10	SE 25	2.5x17	8x8
107.23.10	SF 40 - SF 42	2.5x17	8x8
107.33.10	SD 25 - SD 32	2.5x17	8x8
107.42.10	SD 50	3.2x22	8x8
107.43.10	SD 63 - SD 80	3.2x22	8x8
107.46.10	SF 26 - SF 32	2.5x17	8x8
107.48.10	AD 40	2.5x17	8x8
107.49.10	SF 51	2.5x17	8x8
107.54.10	SF 67	3.2x22	8x8
107.55.10	SF 26 L	2.5x17	8x8
107.73.10	AG 20	1.6x12	8x8
107.81.10	SF 81	3.2x22	8x8
107.84.10	AF 42/51	3.2x22	8x8
107.85.10	AF 26/32	2.5x17	8x8
PITTLER			
107.25.10	PRB 8/25	2.5x17	8x8
107.26.10	PRB 8/32 - PRC 6/32	2.5x17	8x8
107.37.10	DAM 6/50	3.2x22	8x8
107.39.10	DAM 8/32	2.5x17	8x8
107.45.10	PRB 6/50 - PRC 6/50	2.5x17	8x8
107.52.10	PRB 36/6	2.5x17	8x8
107.64.10	PRC 36/6	2.5x17	8x8
107.65.10	DAM 6/32	2.5x17	8x8
107.71.10	PRC 100/4-72/6-50/8	2.5x17	8x8
BSA			
107.59.10	2"	2.5x17	8x8
107.68.10	2" 1/4	2.5x17	8x8
ACME GRIDLEY			
107.12.10	16 m/m	2.5x17	8x8
107.57.10	1" 1/4 - 6 M	2.5x17	8x8
107.74.10	1" 5/8	2.5x17	8x8
TOS / AN			
107.88.10	6/25 A	2.5x17	8x8
107.89.10	6/40 A	2.5x17	8x8
107.90.10	6/63 A	2.5x17	8x8

A RICHIESTA PER ALTRI TIPI DI MACCHINA - ON REQUEST FOR OTHER TYPES OF MACHINE